

TMRWA3L Torque Motor

Electrical specifications

	Symbol	Unit	Free air convection	Water cooling
Winding code : SB				
Continuous torque	T_c	Nm	117	260
Continuous current	I_c	A_{rms}	12	30
Stall torque	T_s	Nm	82	182
Stall current	I_s	A_{rms}	8.4	21
Peak torque(for 1sec.)	T_p	Nm	300.5	490
Peak current(for 1sec.)	I_p	A_{rms}	36	81
Torque constant	K_t	Nm/Arms	9.79	
Electrical time constant	T_e	ms	10	
Resistance (line to line at 25°C)	R_{25}	Ω	0.89	
Inductance (line to line)	L	mH	8.93	
Number of poles	2p		66	
Back emf constant (line to line)	K_v	Vrms/rad/s	5.65	
Motor constant (at 25°C)	K_m	Nm/ \sqrt{W}	8.44	
Thermal resistance	R_{th}	K/W	0.49	0.079
Thermal sensor			PTC SNM100+SNM120+Pt1000	
Max. DC BUS		V_{DC}	750	
Inertia of rotor	J	kgm^2	0.065	
Thermal time constant	T_{th}	s	3020	280
Max. continuous power dissipation	P_c	W	263	1647
Max. peak power dissipation	P_p	W	12006	
Rated speed(at 600VDC)		rpm	270	

Mechanical specifications

	Symbol	Unit	Free air convection	Water cooling
Mass of rotor	M_r	kg	3.1	
Mass of stator	M_s	kg	20.1	
Height of stator	H_s	mm	90	
Height of rotor	H_r	mm	31	
Length of rotor centring fit	H	mm	10	
Water temperature difference for P_c	$\Delta\theta$	K	-	5
Minimum water flow	q	l/min	-	4.8
Max. pressure drop	Δp	bar	-	1

T-N curve

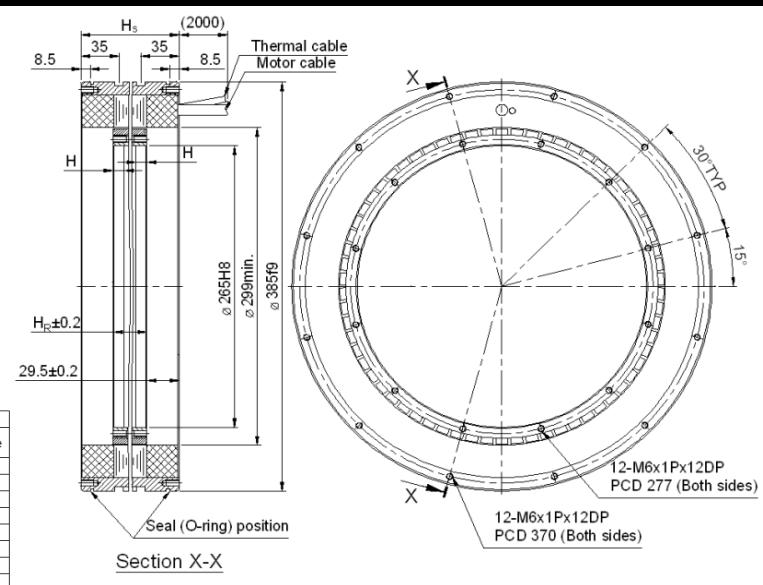
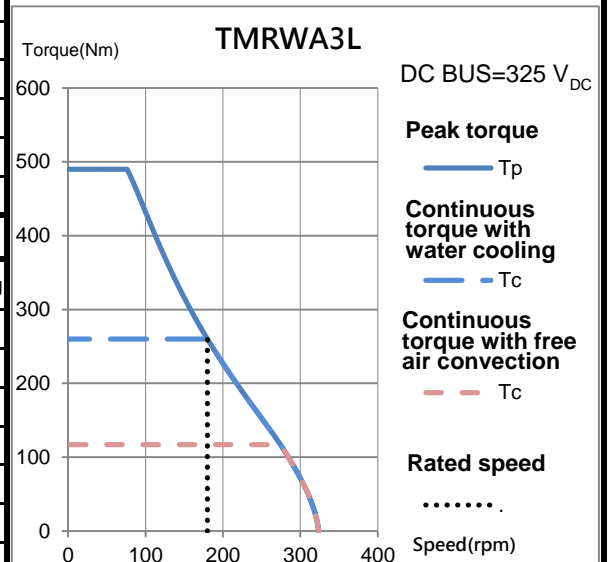
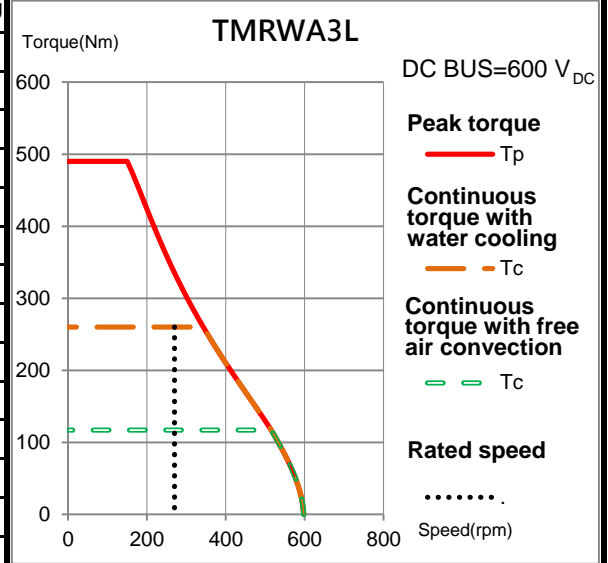

Nominal dimension	Tolerance
~ 6	±0.1
> 6 ~ 30	±0.2
> 30 ~ 120	±0.3
> 120 ~ 300	±0.4
> 300 ~ 600	±0.5
> 600 ~ 1200	±0.8
> 1200 ~ 2400	±1.0
> 2400	±1.5

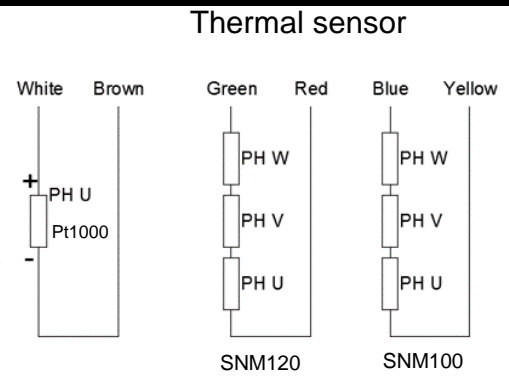

Color or wire no.	Signal
U/L1	PH U
V/L2	PH V
W/L3	PH W
Green/Yellow	GND

Except dimensions, all the specifications in the table are in ±10% of tolerance
This drawing is only for reference, detail dimensions please refer to approval drawing.

Version: 2.00
Date: 2020/10/23