



Assembly instructions

Rotary tables DMS and DMN

TM-02-5-EN-2211-MA

Imprint

HIWIN GmbH

Brücklesbünd 1

D-77654 Offenburg, Germany

Phone +49 (0) 7 81 9 32 78-0

Fax +49 (0) 7 81 9 32 78-90

info@hiwin.de

www.hiwin.de

All rights reserved.

Reprinting, even in part, is not permitted without our approval.

These assembly instructions are protected by copyright. Written permission is required from HIWIN GmbH for any duplication, publication in whole or in part, alterations or abridgement.

Contents

1	General information	5
1.1	About these assembly instructions	5
1.2	Presentation and layout conventions used in these assembly instructions	5
1.3	Warranty and liability	6
1.4	Manufacturer information	7
1.5	Product monitoring	7
2	Basic safety information	8
2.1	Proper use	8
2.2	Reasonably foreseeable misuse	8
2.3	Conversions or modifications	8
2.4	Residual risks	8
2.5	Requirements for personnel	9
2.6	Safety equipment	9
2.7	Markings on the rotary tables	9
3	Description of rotary table	10
3.1	Application	10
3.2	Main components of the rotary table (example DMS3x)	10
3.3	Functional description	10
3.4	Versions	11
3.5	Protective plate (option)	11
3.6	Parking brake (option)	12
4	Transport and setup	14
4.1	Delivery DMS, DMN	14
4.2	Transport to the installation location	14
4.3	Installation location requirements	14
4.4	Storage	14
4.5	Unpacking and setup	15
5	Assembly and connection	16
5.1	Assembly of rotary tables	16
5.2	Mounting the moving load	16
5.3	Electrical connection	17
6	Commissioning	24
6.1	Switching on rotary table	24
6.2	Programming	24
7	Maintenance and cleaning	25
7.1	Maintenance	25
7.2	Cleaning	26
8	Faults	27
8.1	Motor faults	27
8.2	Operating faults with a servo drive	27
9	Disposal	28
10	Appendix 1: Order codes	29
10.1	Order code DMS	29
10.2	Order code DMN	29

11 Installation certificate 30

1 General information

1.1 About these assembly instructions

1.1.1 Requirements

We assume that

- The operating personnel have been instructed in the safe operation of the rotary tables and have read and understood these assembly instructions in full
- Maintenance personnel maintain and repair the rotary tables in such a way that they present no danger to persons, the environment or property

1.1.2 Availability

Ensure that these assembly instructions are available at all times to persons working on or with the rotary tables.

1.2 Presentation and layout conventions used in these assembly instructions

1.2.1 Instructions for actions

Instructions for actions are provided in sequential order and identified with a triangle symbol. The results of the actions are accompanied by a tick symbol.

Example:

- ▶ Position the rotary table on the mounting holes.
- ▶ Insert mounting bolts into mounting holes and tighten in spiral sequence with a torque of 10 Nm.
- ✓ The rotary table is mounted.

1.2.2 Lists

Lists are identified through the use of bullet points.

Example:

- Rotary tables must not be operated: Outdoors
- In areas where there is a risk of explosion
- ...

1.2.3 Presentation of safety information

Safety information is always indicated by a signal word and sometimes with a hazard-specific symbol (see section 1.2.4 Symbols used).

The following signal words/hazard levels are used:

 **Danger!** Immediate danger!

 Failure to follow this safety instruction will result in severe or fatal injury!

 **Warning!** Potentially dangerous situation!

 Failure to follow this safety instruction could result in severe or fatal injury!

 **Attention!** Potentially dangerous situation!

 Failure to follow this safety instruction could result in moderately severe or minor injury!



 **Caution!** Potentially dangerous situation!

 Failure to follow this safety instruction could result in damage to property or the environment!



1.2.4 Symbols used

The following symbols are used in these assembly instructions and on the rotary tables:

Warning symbols

	Warning of electric shocks!		Warning of hot surfaces!
	Environmentally hazardous substance!		

Instruction symbols

	Wear safety gloves!		Disconnect before maintenance or repair work.
---	---------------------	---	---

1.2.5 Information

Note:

Provides general information and recommendations.

1.3 Warranty and liability

The manufacturer's "General Terms and Conditions of Sale and Delivery" apply.

1.4 Manufacturer information

Address	HIWIN GmbH Brücklesbünd 1 77654 Offenburg, Germany
Telephone	+49 (0) 781 / 9 32 78 - 0
Technical customer service team	+49 (0) 781 / 9 32 78 - 77
Fax	+49 (0) 781 / 9 32 78 - 90
Technical customer service team fax	+49 (0) 781 / 9 32 78 - 97
E-mail	info@hiwin.de
Internet	www.hiwin.de

1.5 Product monitoring

Please inform HIWIN, as the manufacturer of the rotary tables, about:

- Accidents
- Possible sources of danger at the rotary tables
- Any unclear information in these assembly instructions

2 Basic safety information

Note:

There are no magnetic fields in the vicinity of complete rotary tables.

Note:

With IP65 version according to DIN 40050/IEC 529/VDE 0470/EN 60529:

Ensure that the materials used are chemically resistant to the ambient atmosphere/liquid:

Housing: Anodised aluminium; with DMS3 and DMS7 partly carbon

Plug material: Brass, nickel-plated

Screws: Stainless steel

Seals: NBR (sealing lip)

Protective plate: Stainless steel

2.1 Proper use

The rotary table is a rotating drive and guide system for the exact, time-controlled positioning of permanently mounted loads, such as system components, in an automated system.

Rotary tables are designed for installation and operation in any position, but do not have a parking brake. The loads to be moved must be fixed into position on the rotor.

The rotary tables must not be used outdoors or in hazardous areas where there is a risk of explosions. Rotary tables may only be used as described for the intended purpose.

- Rotary tables may only be operated within their specified performance limits (see "Rotary tables" catalogue).
- The assembly instructions and the maintenance and servicing instructions must be complied to ensure the intended use of the rotary tables.
- Any other use of the rotary tables is considered improper use.
- Only original spare parts from HIWIN GmbH may be used.

2.2 Reasonably foreseeable misuse

Rotary tables must not be operated:

- Outdoors
- In areas where there is a risk of explosion

2.3 Conversions or modifications

Conversions or modifications to the rotary tables are not permitted!

2.4 Residual risks

No residual risks emanate from the rotary tables during normal operation. Dangers that may arise during maintenance and servicing are specified in the respective chapters.

2.5 Requirements for personnel

Only authorised and competent persons may carry out work on the rotary tables! They must be familiar with the safety equipment and regulations before they start work (see following table).

Activity	Qualifications
Normal operation	Instructed personnel
Cleaning	Instructed personnel
Maintenance	Qualified personnel of the operator or manufacturer
Servicing	Qualified personnel of the operator or manufacturer

2.6 Safety equipment

2.6.1 Personal protective equipment

Table 2.1: Personal protective equipment

Operating phase	Personal protective equipment
Normal operation	The following personal protective equipment is required when standing or working near the rotary tables: ○ Safety shoes
Cleaning	The following personal protective equipment is necessary when cleaning the rotary table: ○ Safety shoes
Servicing and maintenance	The following personal protective equipment is necessary during maintenance and servicing: ○ Safety shoes

2.7 Markings on the rotary tables

2.7.1 Type plate

Fig. 2.1: Type plate (example)

 HIWIN GmbH Brücklesbünd 1 77654 Offenburg www.hiwin.de	Type: DMS34-A00	
	S/N: HSN0000001999	
	Art. No: 7.R2250	Year built: 2017
	Rated current I_C : 3.4A	Mass of table: 7kg
	Rated torque T_C : 20.0Nm	Max. DC bus: 600VDC
Max. current I_p : 10.2A	Temp.sensor: PTC120	
Max. torque T_p : 60.0Nm	Protection class: IP40	

3 Description of rotary table

3.1 Application

The rotary table is a rotating drive and guide system for the exact, time-controlled positioning of permanently mounted loads, such as system components, in an automated system. Rotary tables are designed for installation and operation in any position, but do not have a parking brake. The loads to be moved must be fixed into position on the rotor.

3.2 Main components of the rotary table (example DMS3x)

Fig. 3.1: Main components of a rotary table

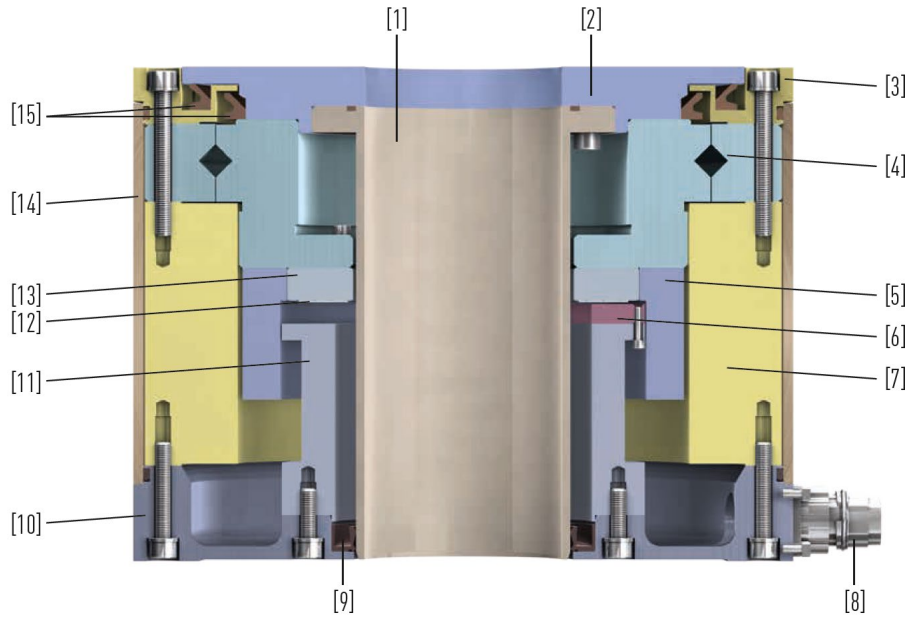

Table 3.1: Main parts of a rotary table

1	Hollow shaft	6	Encoder	11	Carrier for encoder
2	Upper housing cover (rotor)	7	Stator	12	Raster disc
3	Upper housing ring (stator)	8	Receptacle	13	Support for raster disc
4	Crossed roller bearings	9	Seal	14	Motor housing
5	Rotor	10	Lower housing cover	15	Seal

3.3 Functional description

The rotary table is driven by a 3-phase, permanently excited torque motor. The integrated bearing absorbs loads and torques and transfers them to the machine bed. The integrated distance measuring system provides a standardised sin/cos-1 VSS output signal. The rotary table is operated with a suitable servo drive.

3.4 Versions

3.4.1 DMS

Key features:

- Backlash-free and extremely dynamic
- Brushless and high torque
- Integrated optical encoder

Typical applications:

- Automation technology
- Pick and Place

3.4.2 DMN

Key features:

- Backlash-free and extremely dynamic
- Brushless and high torque
- Integrated optical encoder

Typical applications:

- Automation technology
- Pick and Place

For information on the torque motors suitable for the HIWIN rotary tables, please refer to the "Torque motors DMR, TMRW" assembly instructions. These are available for download at www.hiwin.de.

3.5 Protective plate (option)

The sealing of the torque rotary tables consists of a labyrinth and sealing lips inserted into it, so-called V-seals. If the rotary table is exposed to abrasive liquids, such as in grinding machines, then this liquid comes into contact with the sealing lips and can damage the sealing lip and its drainage surface.

In order to achieve a sufficient service life of the sealing even when abrasive liquids are used, a stainless steel protective plate is placed on the gap of the labyrinth. This protective plate provides reliable protection against the ingress of liquids when the rotary table is mounted horizontally.

Only in the case of overhead and wall mounting should the protective plate not be used, as it would collect additional liquid and dirt particles in this position.

Note:

The outer diameter of the rotary table increases by 5 mm due to the protective plate.

Fig. 3.2: DMSX – version with optional protective plate

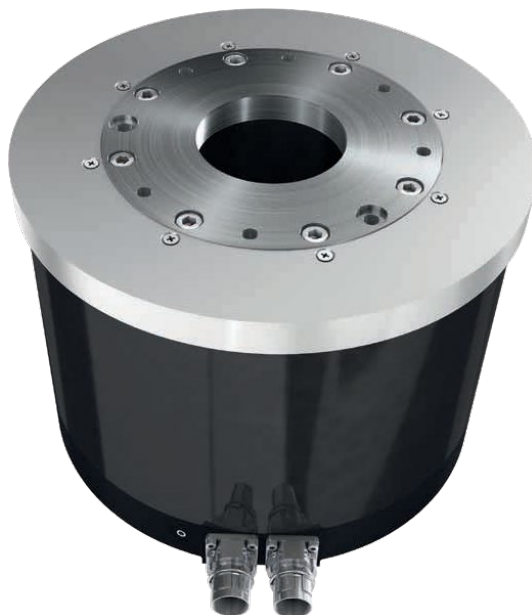

For overhead mounting and for wall mounting combined with abrasive liquids, HIWIN rotary tables are supplied with a sealing air preparation.

For the additional sealing air, 5 of the radial M4 threads (see Fig. 3.3) are sealed with the enclosed grub screws and the sealing air is connected through the 6th threaded hole. The matching push-in fitting is enclosed.

Hose diameter: 4 mm

Air pressure: 0.2 to 0.5 bar

Fig. 3.3: DMS3X – M4 threaded holes

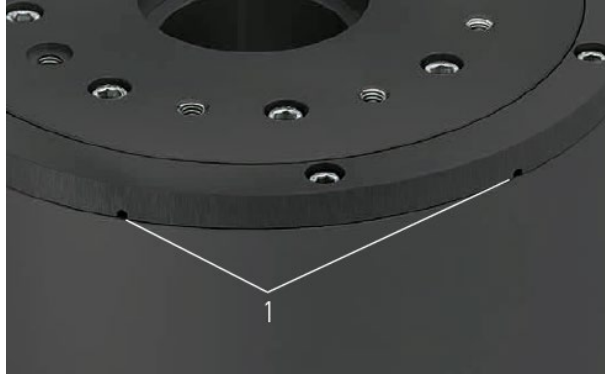

1 M4 threaded holes

3.6 Parking brake (option)

Note:

The parking brake (clamping element) is only used to clamp the stationary shaft in continuous operation.

Note:

The parking brakes are mounted under the housing cover as standard. This changes the dimensions of the rotary table.

Depending on the type, the rotary tables are equipped with a pneumatic parking brake. The brakes used are emergency-activated, i.e. they are activated without pressure. Parking brakes are currently available for the DMS3 series and DMS7 series.

Fig. 3.4: DMS3, view from below on the clamping – view from the front (left) and from the back (right)

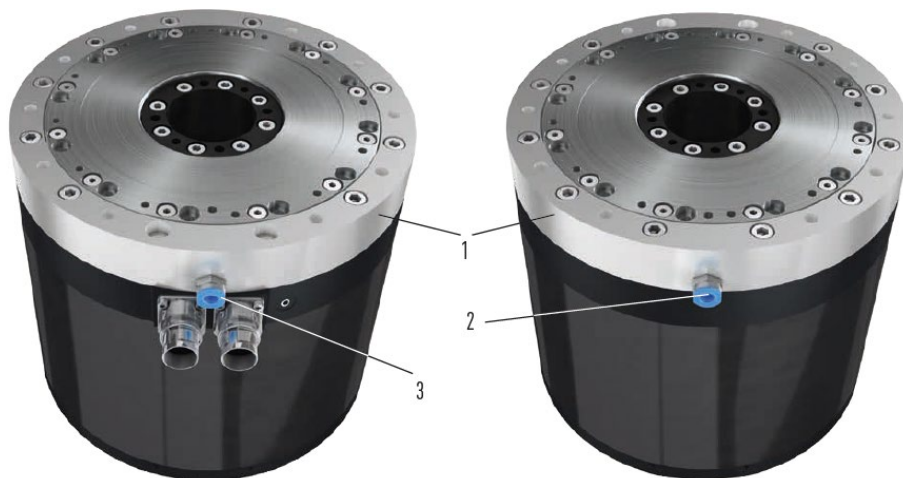

1 Parking brake

2 Rear pneumatic connection

3 Front pneumatic connection

3.6.1 Holding torques

If no supplementary air is connected, the rear valve ("Close") must remain open.
 The holding torques are given in Table 3.2. Without application of air, the parking brakes are closed. The holding torque can be increased by adding air to the rear valve ("Close"), see Fig. 3.5.

Table 3.2: Holding torques of the pneumatic parking brake

Rotary table	DMS3x		DMS7x	
	6 bar	4 bar	6 bar	4 bar
Opened at nominal pressure	6 bar	4 bar	6 bar	4 bar
Holding torque without additional air	114 Nm	114 Nm	336 Nm	336 Nm
Holding torque with additional air	210 Nm	140 Nm	600 Nm	400 Nm

3.6.2 Connection

Note:

To minimise reaction time, the valves should be placed as close as possible to the parking brake. In addition, quick exhaust valves can shorten the reaction time.

The parking brake must be controlled with a 3/2 or 5/2-way valve, as shown in Fig. 3.5. The valves must have a minimum nominal size of G 1/8. The hose connection must not fall below a minimum diameter of 6 mm.

Fig. 3.5: Pneumatic connection of the parking brake

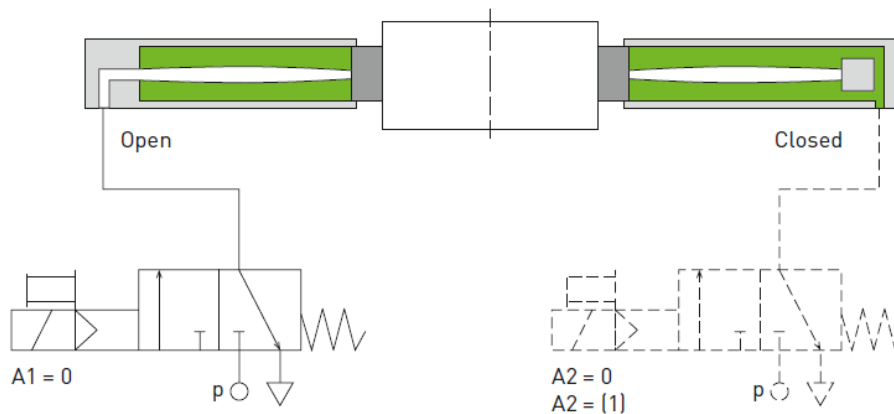

3.6.3 Commissioning

The function of the parking brake is checked by HIWIN before delivery. Before commissioning the rotary table, it must nevertheless be checked to ensure that

- The parking brake is open (check by turning the shaft manually)
- There is no dirt (oil or grease, small solids) between the clamping surfaces

4 Transport and setup

4.1 Delivery DMS, DMN

4.1.1 Delivery condition

The rotary table is delivered fully assembled, functionally tested and ready for connection.

4.1.2 Scope of delivery

For scope of delivery, see contract documentation.

4.2 Transport to the installation location

⚠ Caution! Damage to the rotary table!

The rotary table can be damaged by mechanical stress.

- ▶ Do not transport any additional loads on the rotary table during transport!
- ▶ Secure the rotary table against tipping!
- ▶ Transport the rotary table to the installation site using suitable lifting gear (for weights, see the "Rotary tables" catalogue).
- ▶ Ensure even load distribution when lifting.

4.3 Installation location requirements

4.3.1 Environmental conditions

Ambient temperature	+ 5 °C to + 40 °C
Installation site	Level, dry, vibration-free
Atmosphere	Non-corrosive, non-explosive

4.3.2 Safety equipment to be provided by the operator

Possible safety equipment/measures:

- Personal protective equipment according to UVV
- Electrosensitive protective equipment
- Mechanical safety equipment

4.4 Storage

- ▶ Store the rotary table in the transport packaging.
- ▶ Do not store the rotary table in an explosive atmosphere or in an environment contaminated with chemicals.
- ▶ Store rotary tables only in dry, frost-free rooms with a non-corrosive atmosphere.
- ▶ Make sure that the rotary tables are not exposed to vibrations or impacts during storage.
- ▶ Clean and protect used rotary tables before storage.
- ▶ The ambient temperature when storing the motors is between +5 and +70 °C.

4.5 Unpacking and setup

! **Caution!** Damage to the rotary tables!

Rotary tables can be damaged by mechanical stress.

- ▶ Do not transport any additional loads on the rotary tables during transport!
- ▶ Secure rotary tables against tipping!

Note:

The rotary tables must be set up and operated indoors only.

- ▶ Remove protective film.
- ▶ Carefully transport rotary table to the intended installation site.
- ▶ Ensure that the maintenance points are freely accessible.
- ▶ Dispose of packaging in an environmentally-safe manner.

5 Assembly and connection

⚠ **Danger!** Danger due to electrical voltage!

Dangerous currents may flow before and during assembly, disassembly and repair work.

- ▶ Work may only be carried out by qualified electricians when the device is de-energised!
- ▶ Before working, disconnect the linear motor system from the power supply and secure them against being switched on again!

⚠ **Danger!** Danger due to electrical voltage!

Electrical superstructures are not safely earthed via the rotary table.

- ▶ Secure electrical superstructures via separate earthing!

⚠ **Warning!** Danger from heavy loads!

Lifting heavy loads can cause damage to health.

- ▶ Use appropriately dimensioned lifting equipment for positioning heavy loads!
- ▶ Comply with the applicable industrial safety regulations for handling suspended loads.

⚠ **Caution!** Damage to the rotary tables!

Rotary tables with protection class IP40 can be damaged by liquids.

- ▶ Clean rotary tables only with a damp cloth!

Note:

Assembly of the rotary tables only by qualified personnel.

5.1 Assembly of rotary tables

Note:

The rotary table is attached from below as standard.

- ▶ Drill the mounting holes on the mounting surface according to the dimensional drawing (see "Rotary tables" catalogue).
- ▶ Clean the mounting surface.
- ▶ Position the rotary table on the mounting holes.
- ▶ Insert the mounting bolts into the mounting holes and tighten them crosswise while observing the permissible torque.
- ✓ The rotary table is mounted.

5.2 Mounting the moving load

- ▶ Clean the mounting surface for the load on the rotary table.
- ▶ Clean the mounting surface on the load.
- ▶ Position the load on the rotary table.
- ▶ Insert the mounting bolts and tighten them crosswise while observing the permissible torque.
- ▶ Manually check the freedom of movement of the load over the entire travel angle.
- ✓ Moving load is mounted.

5.3 Electrical connection

⚠ Danger! Danger due to electrical voltage!

If the rotary table motor is not properly earthed, there is a risk of electric shock.

- ▶ Make sure that the electrical power supply of the rotary table is properly earthed before connecting it!

⚠ Danger! Danger due to electrical voltage!

Electrical currents can also flow when the motor is not moving.

- ▶ Make sure that the rotary table is disconnected from the power supply before disconnecting the electrical connections of the motors!
- ▶ After disconnecting the servo drive from the power supply, wait at least 5 minutes before touching live parts or loosening connections!
- ▶ To be on the safe side, measure the voltage in the intermediate circuit of the servo drive until it has fallen below 40 V.

Note:

Observe the separate assembly instructions for the servo drive!

5.3.1 Direction of rotation

If the motor cable is connected according to [Table 5.1](#), the direction of rotation of the rotor is clockwise (view to the output shaft)

Fig. 5.1: Illustration of the direction of rotation of the rotary table

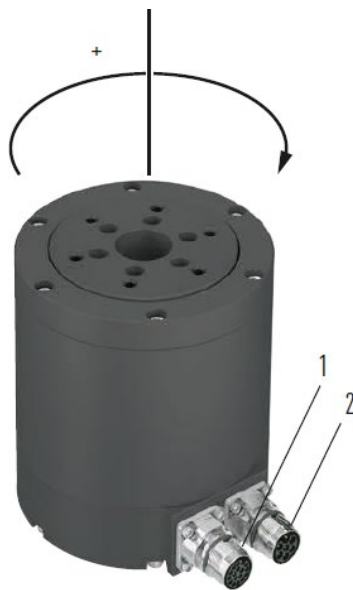

L1 = U, L2 = V, L3 = W

- | | |
|---|-----------------|
| 1 | Motor connector |
| 2 | Encoder plug |

5.3.2 Motor connection

Note:

Maximum length of the supply cable 10 m.

Suitable filters against voltage peaks must be used for longer cables.

Fig. 5.2: Motor connection DMS, DMN



- 1 Motor connector
- 2 Encoder plug

- Brushless 3-phase synchronous motors
- Connection via motor plug (round plug M17, 7-pin)
- Motor plug up to max. 630 VAC
- Motors are designed for intermediate circuit voltage up to 600 VDC
- Suitable for servo drives up to 3 × 400 VAC

Fig. 5.3: PIN assignment of rotary table round plug

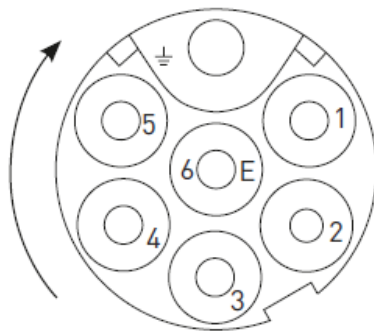

Table 5.1: Pin assignment of rotary table

PIN no.	Signal	Function	Colour of motor extension cable
1	U	Motor phase	Black-1
4	V	Motor phase	Black-2
3	W	Motor phase	Black-3
5	T+	Thermal protection contact	Red
6	T-	Thermal protection contact	Yellow
2		Not assigned	
Protective earth/ground		GND	Green/yellow

5.3.3 Distance measurement

All rotary tables have a position encoder with output signal sin/cos 1 VSS with an index as standard. The position of the index is marked on the housing (see Fig. 5.4).

Fig. 5.4: Index marker for position encoder



H1 = marking of the 0° position ± 15°

5.3.4 Incremental encoder connection

Fig. 5.5: Encoder connection DMS, DMN



1	Motor connector
2	Encoder plug

- Ready-to-operate encoder installed
- Connection via round plug M17, 17-pin
- Encoder is an optical incremental measuring system with sin/cos-1 VSS output signal

Fig. 5.6: PIN assignment of distance measuring system round plug



Table 5.2: PIN assignment of distance measuring system

Round plug connector PIN no.	Output signals of the distance measuring system	Colour of encoder line
1	V 1-	Green
9	V 1+	Yellow
4	Power supply 5 VDC	Red (0.5 mm ²)
2	V 2-	Black
12	GND	Black (0.5 mm ²)
11	V 0-/Ref-	Red
3	V 0+/Ref+	Orange
10	V 2+	Brown
15	Inner shielding	Inner shielding
Plug connector housing	Outer shielding	Outer shielding

Note:

With motor connection according to [Table 5.1](#) and encoder connection according to [Table 5.2](#), the rotary tables of the DMS series have a positive counting direction with positive direction of rotation, the rotary tables of the DMN series have a negative counting direction.

5.3.5 Absolute encoder connection

- Ready-to-operate encoder installed
- Connection via round plug M17, 17-pin
- Encoder is an optical absolute measuring system with sin/cos-1 VSS output signal and EnDat 2.1 interface
- With rotary tables DMS3x-Axxx and DMS7x-Axxx, the encoder has 2048 lines and 13 bit data width (= 8192 increments, corresponding to 156 arcsec resolution).

Fig. 5.7: PIN assignment of distance measuring system round plug

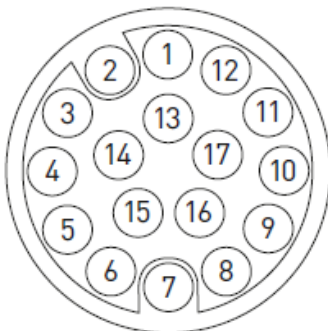

Table 5.3: PIN assignment of distance measuring system

Round plug connector PIN no.	Output signals of the distance measuring system	Colour of encoder line
1	A-	Green
9	A+	Yellow
4	Power supply 5 V Up	Brown/Red (0.5 mm ²)
2	B-	Black
12	GND (0 V Un)	Brown/Blue (0.5 mm ²)
11	Data	Red
3	Data /	Orange
10	B+	Brown
7	CLK	White/Black
6	CKL /	White/Yellow
5	5 V sensor	Grey
13	0 V sensor	Blue
Plug connector housing	Outer shielding	Outer shielding
15	Inner shielding	Inner shielding

Note:

With motor connection according to [Table 5.1](#) and encoder connection according to [Table 5.3](#), the rotary tables of the DMS series have a positive counting direction with positive direction of rotation.

5.3.6 Motor and encoder cables

! **Caution!** Danger when using non-approved extension cables!

If cables other than those approved by HIWIN are used, damage and malfunctions may occur on the rotary tables for which HIWIN accepts no liability.

► Only use cables approved by HIWIN!

Motor cables

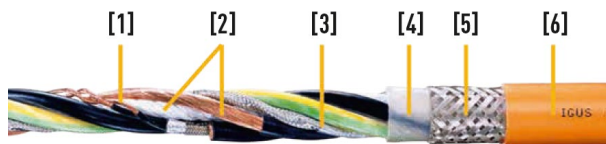

- [1] High bending strength of special ladder
- [2] Energy conductor with the signal pair elements stranded together around high-tensile core cord
- [3] Extremely high flexural strength pair braided copper screen
- [4] Gusset-filling extruded
- [5] Highly bend-resistant braided copper shielding
- [6] Pure mixture extruded with pressure

- For highest stress
- PUR outer sheath
- Shielded
- Oil and coolant resistant
- Notch resistant
- Flame retardant
- Hydrolysis and microbe resistant
- PVC- and halogen-free

Source: igus

Igus Chainflex CF27.15.05.04.D one-sided with open cable end, pre-assembled on the motor side with coupling suitable for motor round plug M17, 7-pin of motor series DMS and DMN.

Table 5.4: Article numbers for motor cables

Article number	Cable length [m]
8-10-0109	3
8-10-0110	5
8-10-0111	8
8-10-0112	10
8-10-0114	15

Encoder lines (incremental distance measuring systems)



[1]	High-tensile core element
[2]	Fine-wire special conductor
[3]	Cores according to measuring system specification
[4]	Highly bend-resistant braided copper shielding
[5]	Oil-resistant PVC-based compound

- For high stress
- PVC outer sheath
- Shielded
- Oil-resistant
- Flame retardant

Source: igus

Igus Chainflex CF211.002 one-sided with open cable end, pre-assembled on the motor side with coupling suitable for encoder round plug M17, 17-pin of motor series DMS and DMN.

Table 5.5: Article numbers for encoder cables (incremental distance measuring systems)

Article number	Cable length [m]
8-10-0115	3
8-10-0116	5
8-10-0117	8
8-10-0118	10
8-10-0120	15

Encoder cables (absolute distance measuring systems)



- [1] High-tensile core element
- [2] Fine-wire special conductor
- [3] Cores according to measuring system specification
- [4] Highly bend-resistant braided copper shielding
- [5] Oil-resistant PVC-based compound

- For high stress
- PVC outer sheath
- Shielded
- Oil-resistant
- Flame retardant

Source: igus

Igus Chainflex CF211.001 one-sided with open cable end, pre-assembled on the motor side with coupling suitable for encoder round plug M17, 17-pin of motor series DMS and DMN.

Table 5.6: Article numbers of encoder cables (absolute distance measuring systems)

Article number	Cable length [m]
8-10-0315	3
8-10-0316	5
8-10-0317	8
8-10-0318	10
8-10-0320	15

5.3.7 Power supply for servo drive – typical values

Note:

Observe the assembly instructions for the servo drive used.

- The minimum cross-section of the mains supply cable is based on the local regulations (see VDE 0100 part 523, VDE 0298 part 4), the ambient temperature and the required nominal voltage of the servo drive.

Table 5.7: Typical values for the power supply

Amplifier nominal current [A]	Connected load [kVA]	Max. cable cross-section of the clamping elements [mm ²]	Recommended fuse (gL) [A]
4.0	1.7	2.5	1 × 10
5.5	2.3	2.5	1 × 16
5.7	4.2	2.5	3 × 10
10.0	7.3	2.5	3 × 16
17.0	12.4	4.0	3 × 25

5.3.8 Function and connection of the temperature sensors

Connection to the servo drive

The temperature monitoring circuits can normally be connected directly to the drive control. If the specifications of the protective separation according to EN 61800-5-1 are to be fulfilled, the sensors must be connected to the decoupling modules offered by the drive manufacturers.

6 Commissioning

6.1 Switching on rotary table

⚠ Warning! Risk of burns!

- Motor heating can cause burns if the motor is touched!
- ▶ Provide protective device and warnings on the motor!

ⓘ Caution! Danger of property damage!

- Risk of property damage due to uncontrolled movement of the rotor in case of power failure!
- ▶ Make sure that suitable end stops are fitted to the end positions or that the parking brake (optional) is activated.

Note:

On the operator's side, a control system in accordance with DIN EN ISO 12100 must be provided to prevent unintentional start-up of the machine after energy has been restored, a fault has been rectified or the machine has stopped.

- ▶ Switch off control system.
- ▶ Remove motor cable.
- ▶ If necessary, connect the cable of the distance measuring system (see section [5.3.4](#) or [5.3.5](#)).
- ▶ Switch on control system.
- ▶ If necessary, check the distance measuring system (see separate assembly instructions for servo drive and distance measuring system).
- ▶ Switch off control system.
- ▶ Connect the motor cable (see section [5.3.1](#)).
- ▶ Switch on control system.
- ▶ Carry out a trial run at a slow speed.
- ▶ Carry out a trial run under operating conditions.
- ✓ Rotary table is ready for operation.

6.2 Programming

Note:

The programming of the rotary tables depends on the control system used as well as the servo drive. Observe the assembly instructions of the control system and servo drive.

7 Maintenance and cleaning

⚠ Warning! Unauthorised maintenance of the system

Unauthorised work on the unit may cause injury and invalidate the warranty.

- ▶ Have the system serviced by qualified personnel only!

Note:

Only use suitable media that are not dangerous for humans. Observe the manufacturer's safety data sheets.

For maintenance work

- ▶ Secure the rotary table against unauthorised switch-on.
- ▶ Disconnect the rotary table from the power supply.
- ▶ Secure the rotary table against unauthorised restarting.



7.1 Maintenance

Note:

If increased running noises occur after several 100 operating hours, relubrication may be necessary. Contact HIWIN GmbH for this purpose.

The ball or crossed roller bearings installed in the rotary tables require an adequate supply of lubricant, just like any rolling bearing. The lubricants reduce wear, protect against dirt, protect from corrosion and lengthen service life.

The crossed roller bearings used in the rotary tables are equipped with seals that prevent the lubricant from escaping from the bearing.

After the rolling bearings have been mounted, an initial greasing is carried out at the factory. If the rotary table does not heat up disproportionately during operation (higher than 50 °C) and does not require high speeds (higher than 500 rpm), relubrication is normally not necessary.

7.2 Cleaning

⚠ Warning! Aggressive media

There is a risk of injury and damage to the rotary table if aggressive media are used for cleaning.

- ▶ Only use suitable media that are not dangerous for humans!
- ▶ Check safety data sheets!

⚠ Caution! Damage to the rotary tables!

Rotary tables with protection class IP40 can be damaged by liquids.

- ▶ Clean rotary tables only with a damp cloth!

Dirt can accumulate on the rotary tables and stick over time. That is why you must check the rotary tables regularly for dirt and remove it if necessary, e.g. with 70% alcohol.

8 Faults

8.1 Motor faults

Table 8.1: Fault table

Fault	Possible cause	Remedy
Motor will not start	Supply lines interrupted	Check connections, plug connector contacts may be pressed in. Correct if necessary. The plug connectors have a seal, which means that a certain amount of screw resistance needs to be overcome.
	Fuse has been triggered by the motor protection equipment	Check motor protection equipment for the correct setting, or correct the fault
Motor turns in the wrong direction Direction	Encoder setting incorrect	Check settings
	Input phase error	Cross 2 phases of the motor
Burning smell	Setup parameters of the controller are incorrect	1 Check controller settings
	Cooling system not working correctly	2 Check cooling system
	Controller setting does not match the motor parameters	
Malfunction of communication	Motor phase connected incorrectly	Check servo drive, target value
Motor is humming and has a high power input	Rotor blocked	Check motor for smooth running
	Brake blocked	Check air pressure or power supply
	Fault on encoder line	Check encoder line
	Problem with motor insulation	Check resistance values > 50 MΩ (phase/earth and phase/sensor)
Motor is heating up too much (measure temperature)	Controller setting incorrect	Check controller settings
	Overload	Measure power. If necessary, use larger motor or reduce load
	Insufficient cooling	Adjust cooling air supply or clear cooling air paths. If necessary, retrofit fans
	Ambient temperature too high	Note permissible temperature range
	Nominal operating mode exceeded, e.g. due to excessive duty cycle	Adjust the motor's nominal operating mode to suit the required operating conditions
	Bearing damage	Check bearing
Unnatural friction noise or friction torque too high	Problem with centring of the motor	Check installation
	Contamination of air gap	Remove contamination

8.2 Operating faults with a servo drive

When operating the rotary table with servo drive, the faults described in section [8.1 Motor faults](#) can also occur. You will find explanations of the faults that occur and information on how to resolve them in the assembly instructions for the respective servo drive.

9 Disposal

! **Caution!** Environmentally hazardous substances!

The risk posed to the environment depends on the type of materials used.

- ▶ Always clean contaminated components before disposal!
- ▶ Clarify proper disposal with disposal companies and, if necessary, with the responsible authorities!

Liquids	
Lubricants	Dispose of as hazardous waste in an environmentally-safe manner
Soiled cleaning cloths	Dispose of as hazardous waste in an environmentally-safe manner
Rotary table	
Cabling, electrical components	Dispose of as electrical waste
PP components	Sort by type before disposal
Aluminium components (housing)	Sort by type before disposal
Iron components	Sort by type before disposal
Copper components	Sort by type before disposal
Brass components, nickel-plated (plug connector material)	Sort by type before disposal
NBR components (seals)	Sort by type before disposal
Stainless steel components (screws)	Sort by type before disposal

10 Appendix 1: Order codes

10.1 Order code DMS

Number	1	2	3	4	5	6	7	8	9
Order code	DM	S	3	4	L	A	0	0	0
1	DM	Torque motor							
2	S	Type: S: Rotary table complete with cross roller bearing							
3	3	Outer diameter [mm] 0: 110 1: 150 3: 200 7: 300							
4	4	Rotor height [mm]: 2: 20 3: 30 4: 40 6: 60 7: 70 8: 80 C: 120							
5	L	Winding variant: None: Standard winding L: For high rotary speed							
6	A	Distance measuring system: A: Optical, incremental (DMS0, DMS1, DMS3) D: Optical, incremental (DMS7)							
7	0	Clamping element: 0: Without							
8	0	Protection class: 0: IP40							
9	0	Special equipment: 0: Without							

10.2 Order code DMN

Number	1	2	3	4	5
Order code	DM	N	7	1	E
1	DM	Torque motor			
2	N	Type: N: Rotary table complete, flat design			
3	7	Outer diameter [mm] 4: 118 7: 180 9: 230			
4	1	Rotor height [mm]: 1: 10 2: 20 3: 30 5: 50			
5	E	Distance measuring system: E: Encoder			

11 Installation certificate

According to **Machinery Directive 2006/42/EC (Annex II A)**
(translation of the original EC Declaration of Conformity)

Name and address of the manufacturer:

HIWIN MIKROSYSTEM CORP
No.6, Jingke Central Rd.,
Taichung Precision Machinery Park,
Taichung 40852, Taiwan

This declaration refers exclusively to the products in the state in which it is placed on the market and expressly excludes components added and/or modifications made to the products by the user at a later date. This declaration is null and void if changes are made to the product without the express consent of the manufacturer.

We hereby declare that the products described below:

Product designation	Linear Motor System
Model/Type:	DMS, DMN, DMY
Year of manufacture	From 2019

Comply with all relevant requirements of the Machinery Directive **2006/42/EU**.
In addition, the products comply with the requirements of EU Directives **2014/30/EU** (EMC Directive), **2011/65/EU** (RoHS Directive), as well as **Delegated Directive (EU) 2015/863** (Amendment to Annex II of Directive 2011/65/EU RoHS Directive).

Applicable harmonised standards:

EN 60034-1	Rotating electrical machines - Part 1: Dimensioning and operating behaviour	2010
EN 60034-5	Rotating electrical machines - Part 5: Protection classes based on the overall design of rotating electrical machines (IP code) – Classification	2006/AC:2010
EN 61000-6-2	Electromagnetic Compatibility (EMC) - Part 6-2: Generic standards – Immunity for industrial environments	2005
EN 61000-6-4	Electromagnetic Compatibility (EMC) - Part 6-4: Basic technical standards - Emission standard for industrial areas	2007/A1:2011

Additional notes:

The described products are intended for installation in machinery and therefore do not satisfy the requirements for a complete machine in the sense of the Machinery Directive. The products may only be put into service when installed as part of a complete machine that complies in its entirety with the provisions of the Machinery Directive.

A safety assessment (electrical and/or mechanical) of the products may only be carried out after installation in a machine for the intended use.

After installation and use as a component of a machine, the products may have an influence on the EMC properties of this machine. The assessment of the EMC behaviour of the complete machine must therefore be carried out by its manufacturer or distributor.

We live motion.

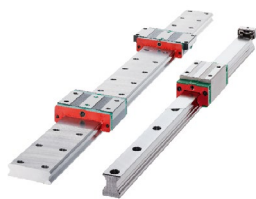

Linear guideways



Ballscrews

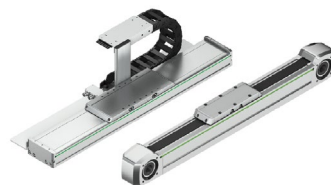

Linear axes

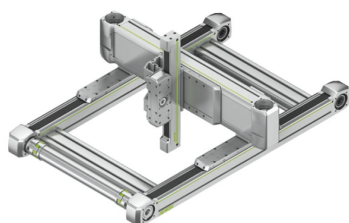

Linear axis systems



Torque motors



Robot

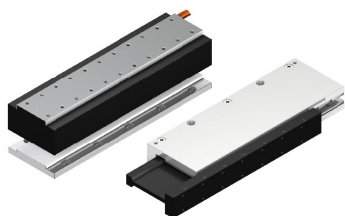

Linear motors



Rotary tables



Servo drives and servo motors

Germany

HIWIN GmbH
Brücklesbünd 1
D-77654 Offenburg, Germany
Phone +49 (0) 7 81 9 32 78 - 0
Fax +49 (0) 7 81 9 32 78 - 90
info@hiwin.de
www.hiwin.de

Taiwan

Headquarters
HIWIN Technologies Corp.
No. 7, Jingke Road
Taichung Precision Machinery Park
Taichung 40852, Taiwan
Phone +886-4-2359-4510
Fax +886-4-2359-4420
business@hiwin.tw
www.hiwin.tw

Taiwan

Headquarters
HIWIN Mikrosystem Corp.
No. 6, Jingke Central Road
Taichung Precision Machinery Park
Taichung 40852, Taiwan
Phone +886-4-2355-0110
Fax +886-4-2355-0123
business@hiwinmikro.tw
www.hiwin.tw

France

HIWIN GmbH
4, Impasse Joffre
F-67202 Wolfisheim
Phone +33 (0) 3 88 28 84 80
contact@hiwin.fr
www.hiwin.fr

Italy

HIWIN Srl
Via Pitagora 4
I-20861 Brugherio (MB)
Phone +39 039 287 61 68
Fax +39 039 287 43 73
info@hiwin.it
www.hiwin.tw

Poland

HIWIN GmbH
ul. Puławska 405a
PL-02-801 Warszawa
Phone +48 22 544 07 07
Fax +48 22 544 07 08
info@hiwin.pl
www.hiwin.pl

Switzerland

HIWIN Schweiz GmbH
Eichwiesstrasse 20
CH-8645 Jona
Phone +41 (0) 55 225 00 25
Fax +41 (0) 55 225 00 20
info@hiwin.ch
www.hiwin.ch

Slovakia

HIWIN s.r.o., o.z.z.o.
Mládežnícka 2101
SK-01701 Považská Bystrica
Phone +421 424 43 47 77
Fax +421 424 26 23 06
info@hiwin.sk
www.hiwin.sk

Czech Republic

HIWIN s.r.o.
Medkova 888/11
CZ-62700 Brno
Phone +42 05 48 528 238
Fax +42 05 48 220 223
info@hiwin.cz
www.hiwin.cz

The Netherlands

HIWIN GmbH
info@hiwin.nl
www.hiwin.nl

Austria

HIWIN GmbH
info@hiwin.at
www.hiwin.at

Romania

HIWIN GmbH
info@hiwin.ro
www.hiwin.ro

Slovenia

HIWIN GmbH
info@hiwin.si
www.hiwin.si

Hungary

HIWIN GmbH
info@hiwin.hu
www.hiwin.hu

Denmark

HIWIN GmbH
info@hiwin.dk
www.hiwin.dk

China

HIWIN Corp.
www.hiwin.cn

Japan

HIWIN Corp.
info@hiwin.co.jp
www.hiwin.co.jp

USA

HIWIN Corp.
info@hiwin.com
www.hiwin.com

Korea

HIWIN Corp.
www.hiwin.kr

Singapore

HIWIN Corp.
www.hiwin.sg